



INSTALLATION MANUAL

## **Kraus Stainless Steel Undermount Kitchen Sink**

KBU10 / KBU11 / KBU12 / KBU14 / KBU15 / KBU16 /  
KBU17 / KBU21 / KBU22 / KBU23 / KBU24 / KBU25 /  
KBU26 / KBU27 / KBU28 / KBU29 / KBU32

## **Congratulations on the purchase of your new Kraus plumbing fixture!**

Please keep the box and packaging materials until your product is completely installed. If you have any questions, require technical assistance or have any problems with your product:



**DO NOT RETURN TO STORE**

**Please contact our Customer Service Team  
1-800-775-0703 / [customerservice@kraususa.com](mailto:customerservice@kraususa.com)**

Have the model number available and retain a copy of your receipt with purchase date for reference.

If for any reason this product does not meet your expectations, please be sure to repack this product in the original box and packaging material to avoid damage during transit.

## Prior to Installation:

- Make sure that you have all necessary parts by checking the parts list. If any part is missing or damaged, please contact Kraus Customer Service at 800-775-0703 for a replacement.
- Inspect the sink prior to installation to make sure that it has not been damaged during shipping.
- Use the cut-out template provided by Kraus.
- Observe all plumbing and building codes according to your state requirements.
- Not recommended to be installed with laminate countertop.

## Parts List

---

- Cut-out Template
- Mounting Hardware
- Bottom Grids
- Drain

**For technical assistance or replacement parts, please contact Kraus**

**Customer Service and one of our representatives will be happy to help:**

Toll-Free: 800-775-0703 or [customerservice@kraususa.com](mailto:customerservice@kraususa.com)

The step-by-step guidelines in the installation instructions are a general reference for installing a Kraus Sink. Should there be any discrepancies, Kraus cannot be held liable. It is recommended to install all Kraus products by hiring a licensed professional.

## Tools you will need:

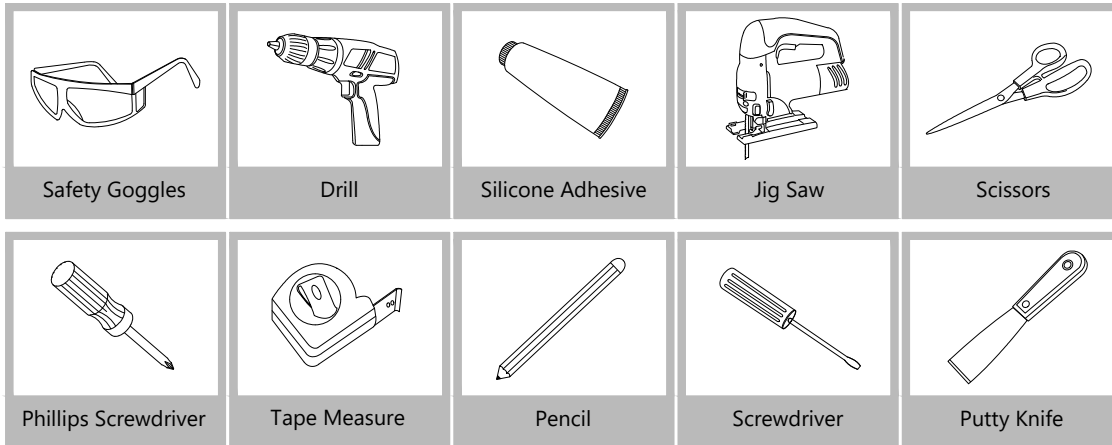

**NOTE:** Specialized tools may be necessary to install Kraus Stainless Steel Undermount sinks with countertop materials other than wood, marble or granite.

## Dimensions

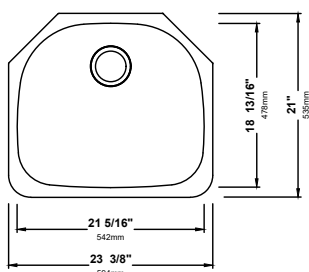

KBU10  
23 3/8" x 21" x 9"  
Min Cabinet Size: 27"  
Matching Grid: KBG-10  
Drain Model #: BST-1

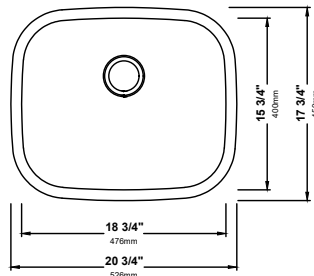

KBU11  
20 3/4" x 17 3/4" x 9"  
Min Cabinet Size: 24"  
Matching Grid: KBG-11  
Drain Model #: ST-1

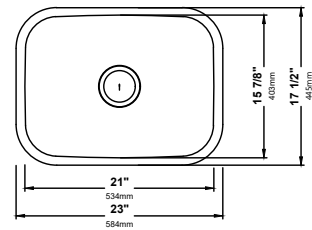

KBU12  
23" x 17 1/2" x 9"  
Min Cabinet Size: 27"  
Matching Grid: KBG-12  
Drain Model #: ST-1

# Dimensions

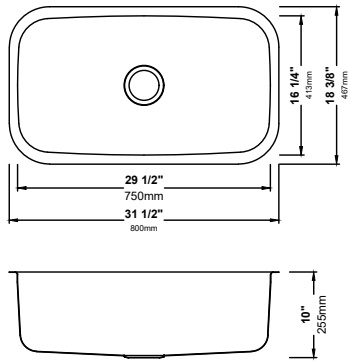

**KBU14**  
 31 1/2" x 18 3/8" x 10"  
 Min Cabinet Size: 36"  
 Matching Grid: KBG-14  
 Drain Model #: BST-1

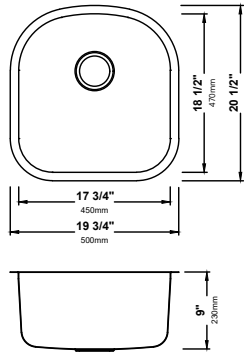

**KBU15**  
 19 3/4" x 20 1/2" x 9"  
 Min Cabinet Size: 24"  
 Matching Grid: KBG-15  
 Drain Model #: BST-1

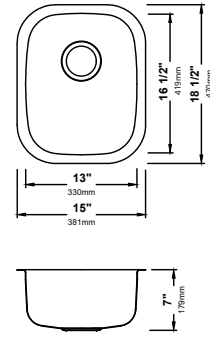

**KBU16**  
 15" x 18 1/2" x 7"  
 Min Cabinet Size: 18"  
 Drain Model #: ST-1

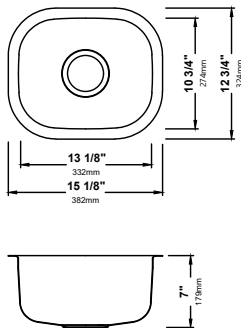

**KBU17**  
 15 1/8" x 12 3/4" x 7"  
 Min Cabinet Size: 18"  
 Drain Model #: ST-1

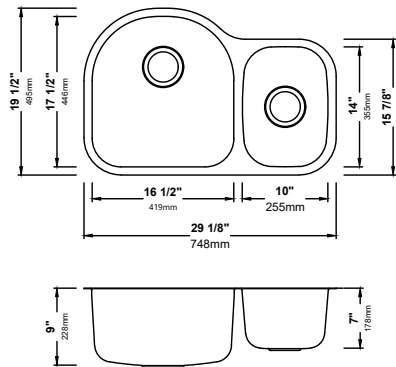

**KBU21**  
 29 1/8" x 19 1/2" x 9"  
 Min Cabinet Size: 33"  
 Matching Grid: KBG-21-1  
 and KBG-21-2  
 Drain Model #: BST-1 & ST-1

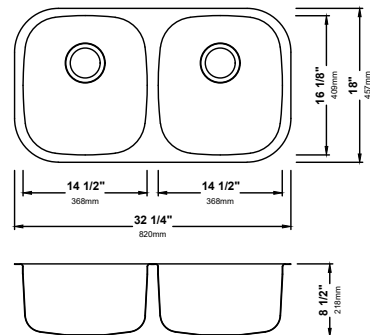

**KBU22**  
 32 1/4" x 18" x 8 1/2"  
 Min Cabinet Size: 36"  
 Matching Grid: KBG-22 (2)  
 Drain Model #: BST-1 & ST-1

# Dimensions

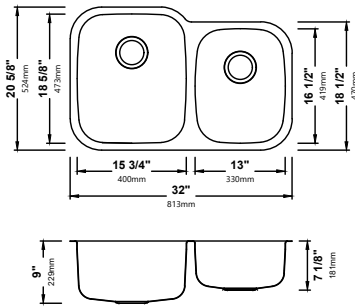

**KBU23**  
 31 1/2" x 20 1/2" x 9"  
 Min Cabinet Size: 36"  
 Matching Grid: KBG-23-1  
 and KBG-23-2  
 Drain Model #: BST-1 & ST-1

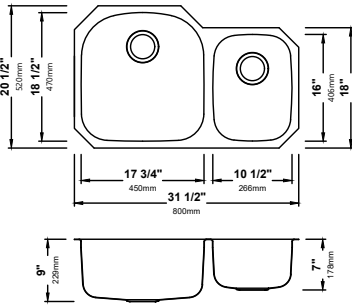

**KBU24**  
 32" x 20 5/8" x 9"  
 Min Cabinet Size: 36"  
 Matching Grid: KBG-24-1  
 and KBG-24-2  
 Drain Model #: BST-1 & ST-1

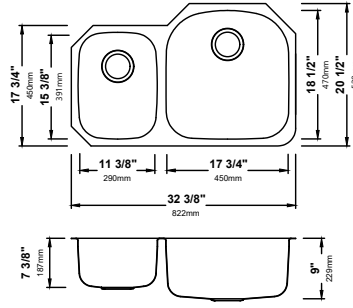

**KBU25**  
 32 3/8" x 20 1/2" x 9"  
 Min Cabinet Size: 36"  
 Matching Grid: KBG-25-1  
 and KBG-25-2  
 Drain Model #: BST-1 & ST-1

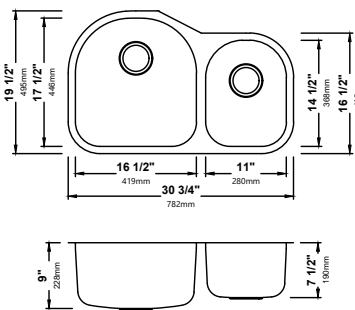

**KBU26**  
 30 3/4" x 19 1/2" x 9"  
 Min Cabinet Size: 36"  
 Matching Grid: KBG-26-1  
 and KBG-26-2  
 Drain Model #: BST-1 & ST-1

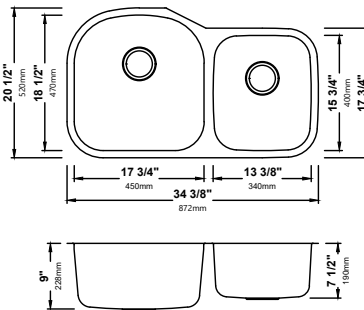

**KBU27**  
 34 3/8" x 20 1/2" x 9"  
 Min Cabinet Size: 39"  
 Matching Grid: KBG-27-1  
 and KBG-27-2  
 Drain Model #: BST-1 & ST-1

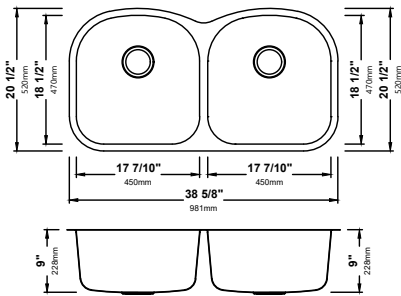

**KBU28**  
 38 5/8" x 20 1/2" x 9"  
 Min Cabinet Size: 42"  
 Matching Grid: KBG-28 (2)  
 Drain Model #: BST-1 & ST-1

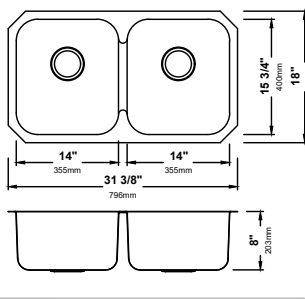

**KBU29**  
 31 3/8" x 18" x 8"  
 Min Cabinet Size: 36"  
 Matching Grid: KBG-29 (2)  
 Drain Model #: BST-1 & ST-1

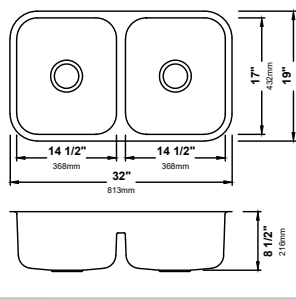

**KBU32**  
 32" x 19" x 8 1/2"  
 Min Cabinet Size: 36"  
 Matching Grid: KBG-32 (2)  
 Drain Model #: ST-1 (2)

# 1. Determine Reveal Type

---

Use scissors to cut along the line of the paper template for your desired reveal type (Negative, Positive or Flushed Reveal).

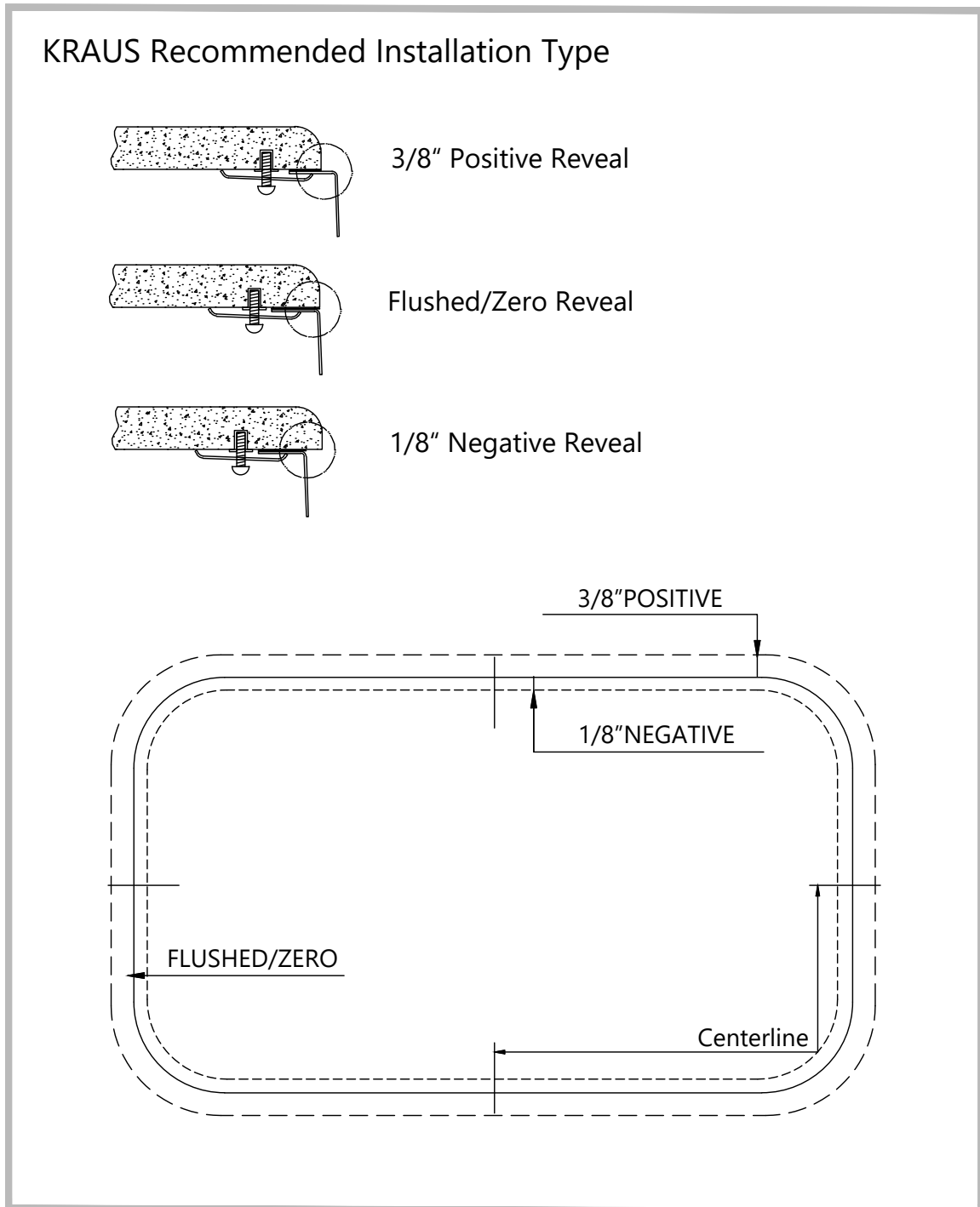

## 2. Position Template

---

- Check the cut-out template against the actual sink to ensure a proper sized cut-out.
- Place the cut-out template in the desired location on the countertop.

**NOTE:** Make sure clearance is suitable for backsplash, faucet and plumbing for the sink.

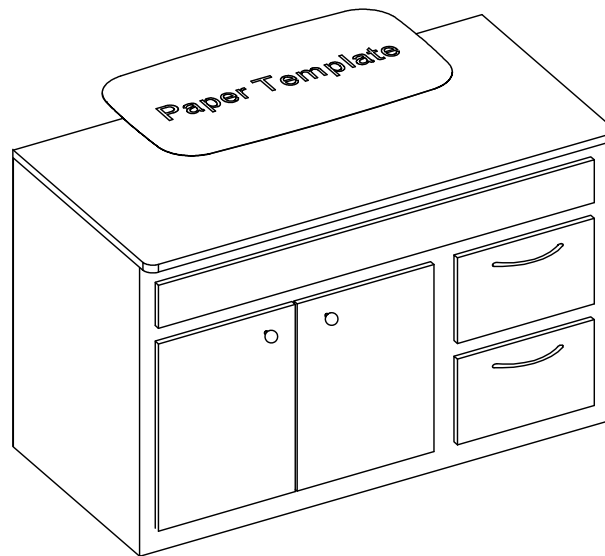

## 3. Trace Template

---

- Trace template on countertop with a pencil.

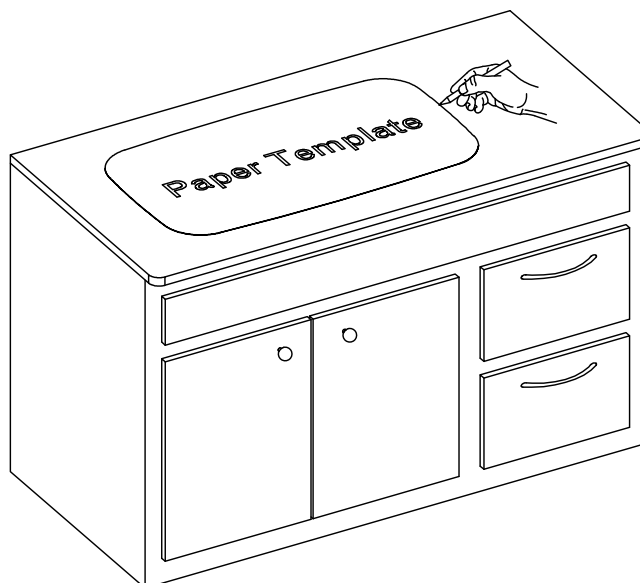



## 4. Cut Countertop

---

- Cut the opening in the countertop by carefully following the traced line.

**NOTE:** Please use the appropriate saw that best fits your countertop material.

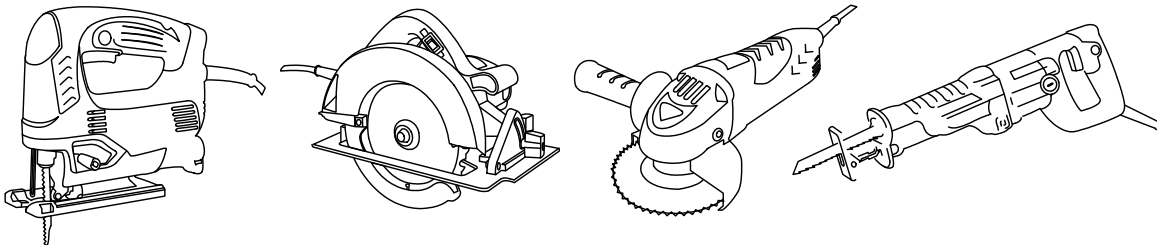
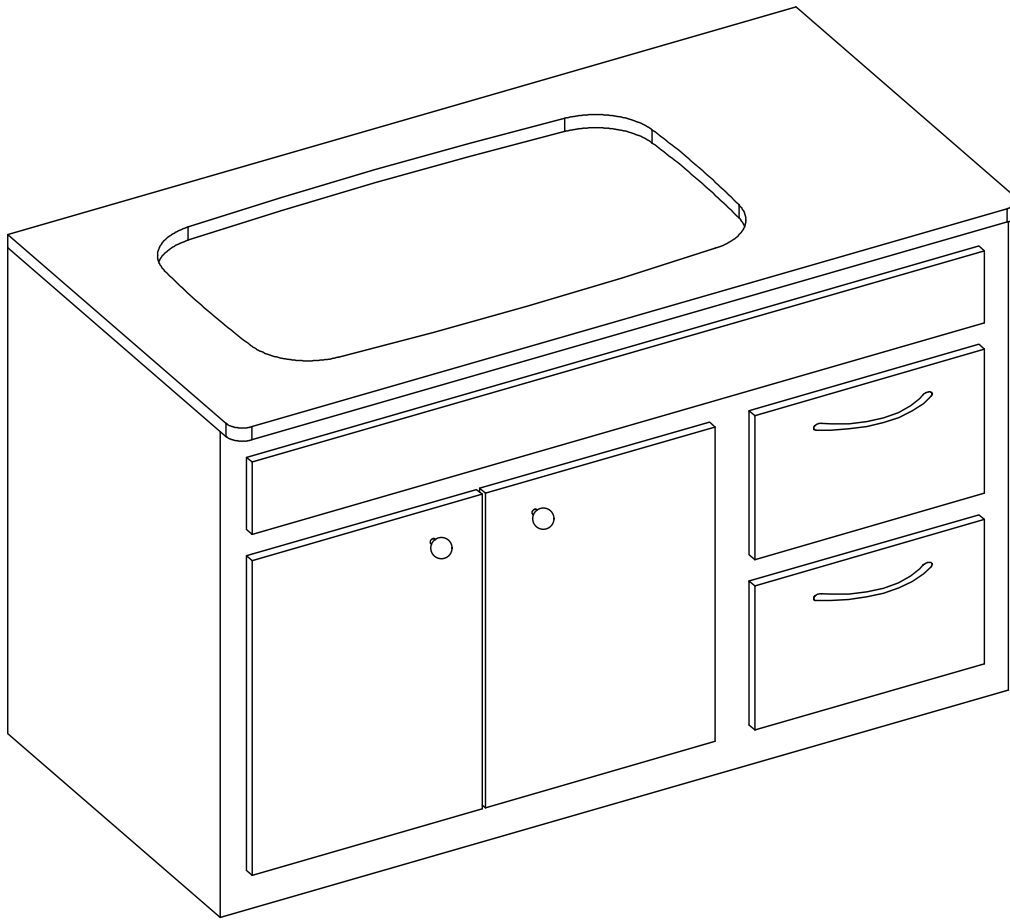

## 5. Set up Mounting Brackets

---

- Turn countertop over and align sink with countertop. Decide location for mounting brackets.
- Mounting holes should be 1/2" from edge of sink.

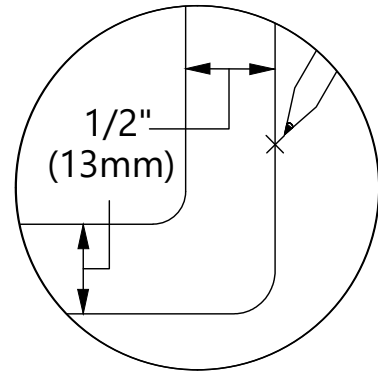
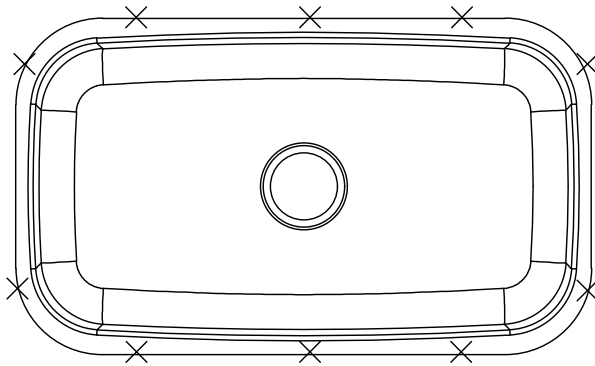

## 6. Drill Hole in Countertop

---

- Drill 3/8" diameter x 1/2" deep hole in countertop.

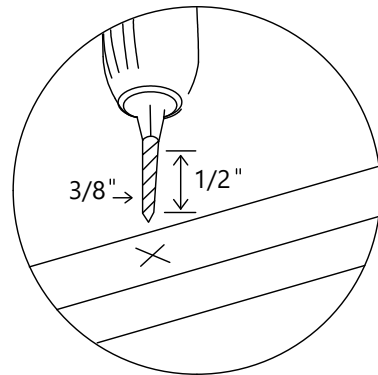
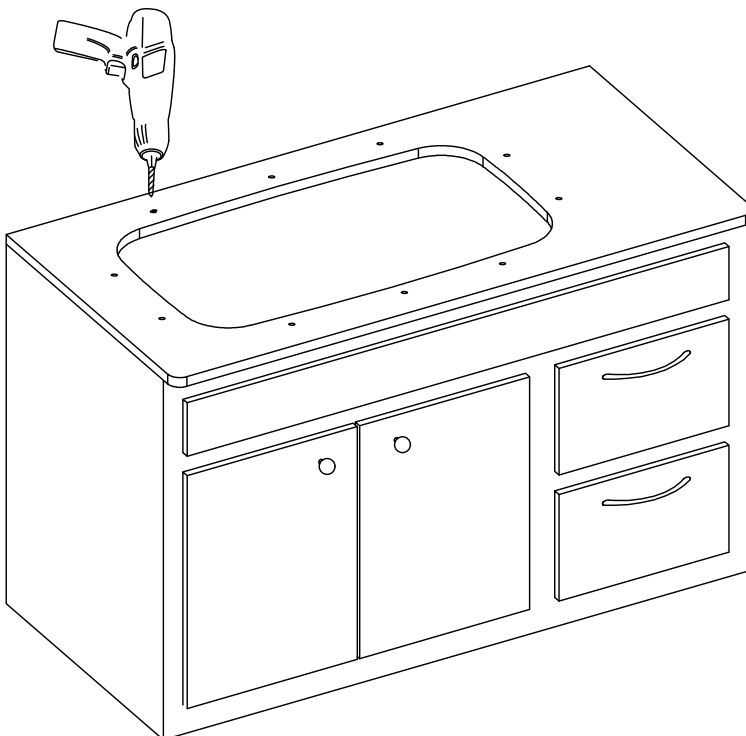

## 7. Install Anchors

---

- Insert anchors into drilled holes and lightly tap with a hammer until flush.

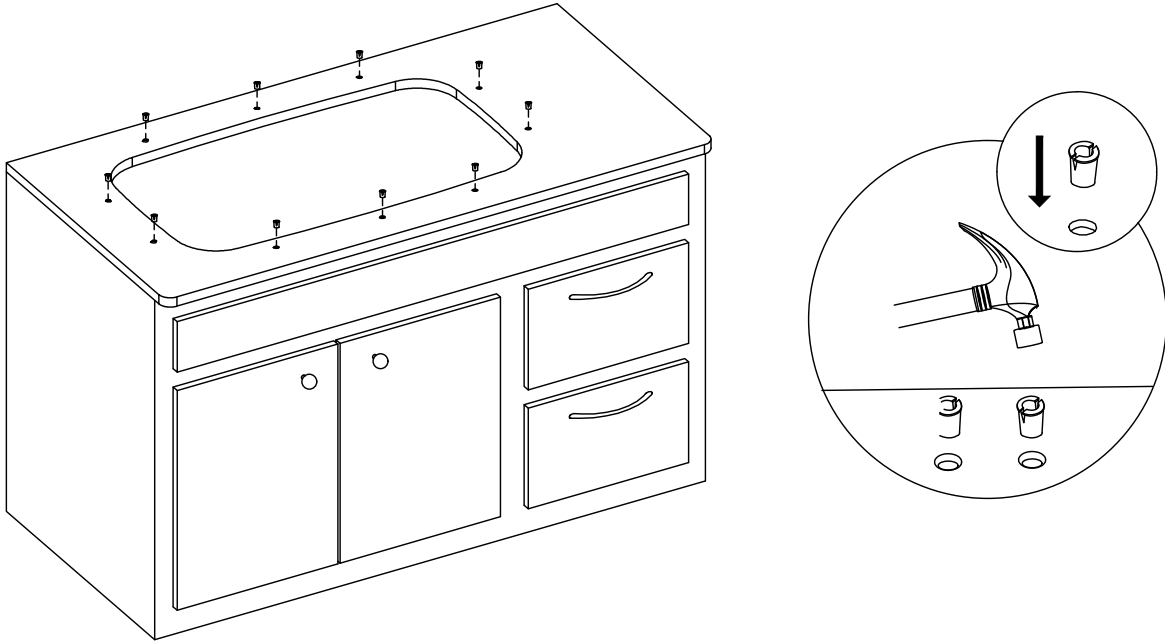

## 8. Secure Sink to Countertop

---

- Use a bead of silicone (or preferred adhesive) around the rim of the sink. Check the alignment of the sink to the cutout in the countertop. Place sink over cutout hole and press firmly.

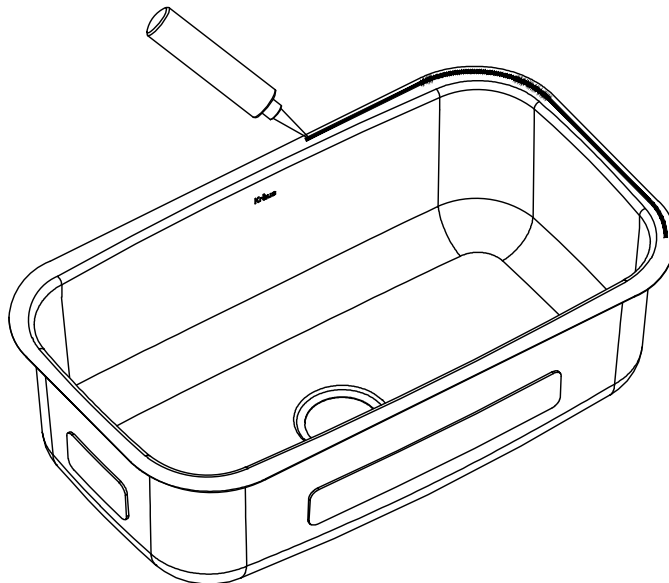

## 9. Attach Mounting Hardware

---

- Attach mounting hardware to secure bowl. Remove excess sealant from inside lip.
- Allow sealant to set for 30 - 60 minutes.

**NOTE:** Use acetone or rubbing alcohol to remove any excess sealant.

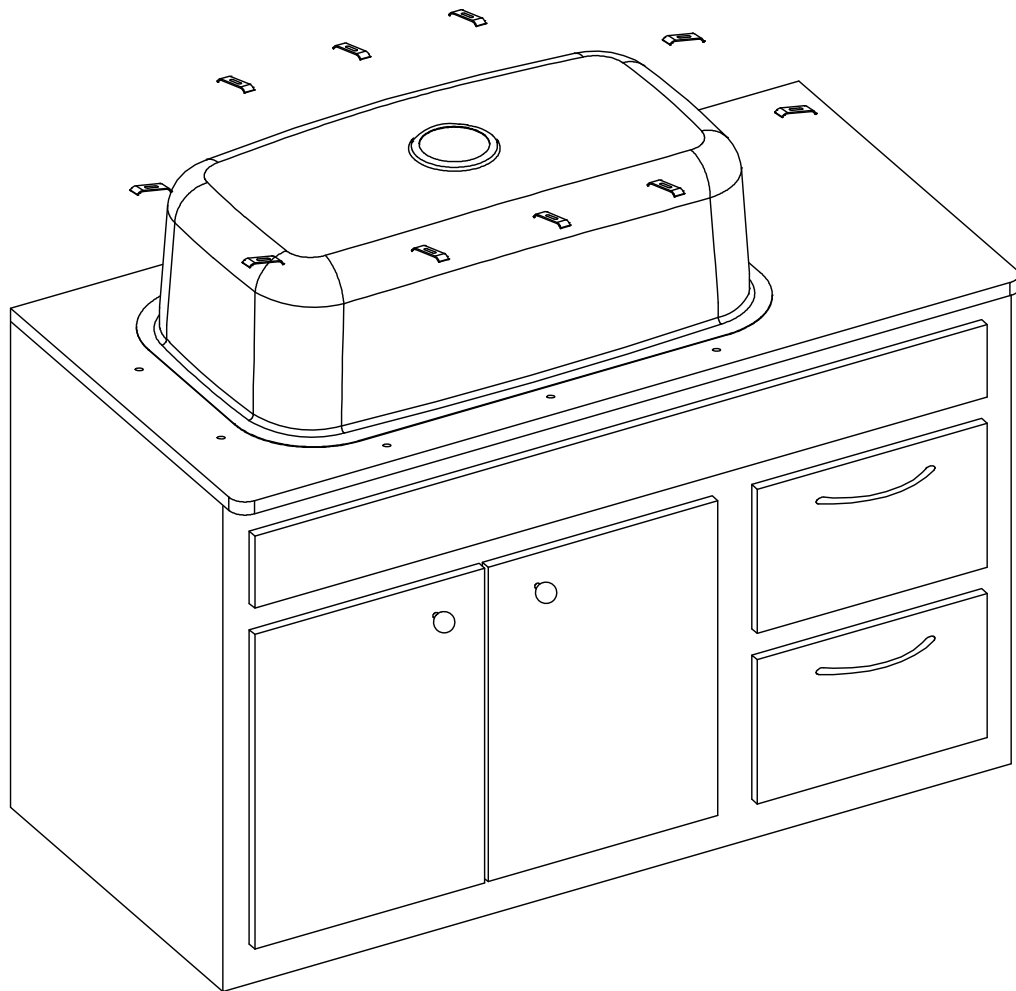

## 10. Install Plumbing Fixtures

---

- Connect drain to sink. Connect trap to drain. Connect water supply connections to faucet according to manufacturer's instructions.
- Run water into sink and check for leaks.
- **Note:** Before installation, please check that the drain kit complies with ASME A112.18.2/CSA B125.2 and with CUPC certification.

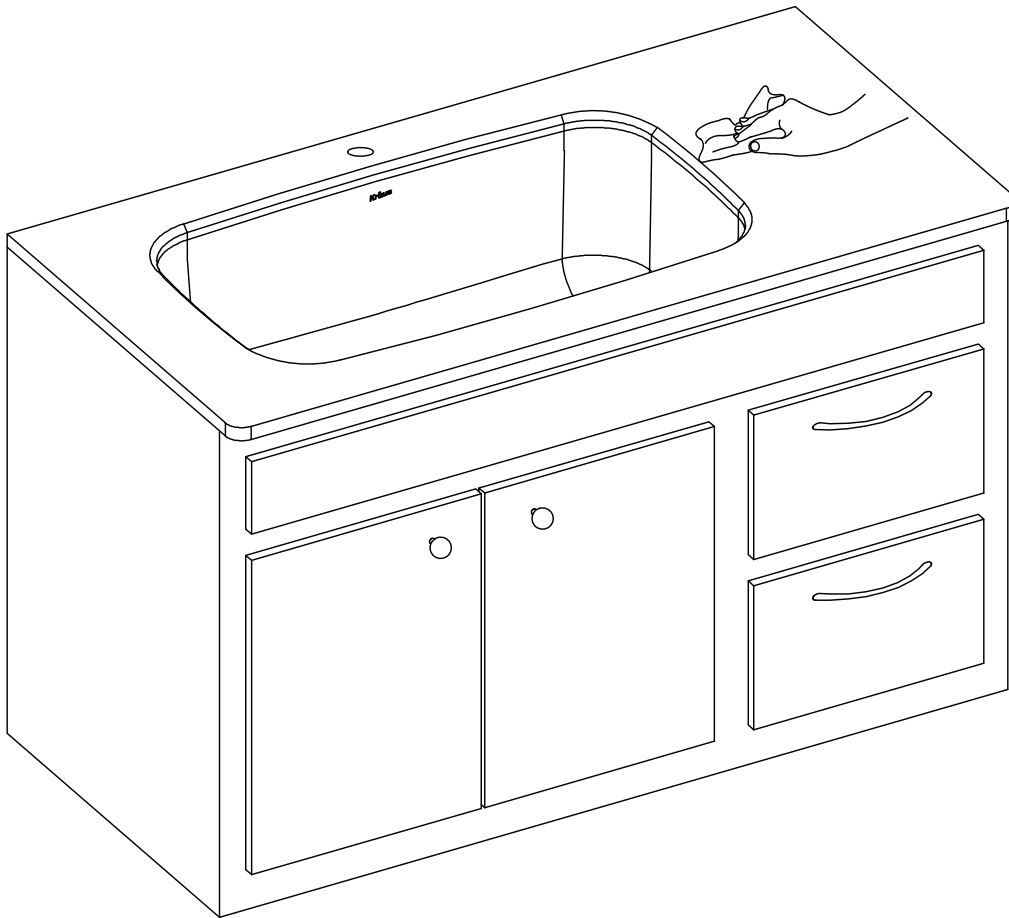

## Codes/Standards Applicable:



---

### Kitchen Sink Warranty

Kraus products are manufactured and tested to the highest quality standards by Kraus USA Inc. ("Kraus").

Kraus extends this warranty to the original purchaser for personal household use of the "Kitchen Sink" in its original location. The warranty is non-transferable.

Kraus warrants the structure and finish of the product to be free from defects in material and workmanship under normal usage for the lifetime of the product. The warranty commences from the initial date of purchase by the owner or trade professional, from an authorized Kraus dealer, through the lifetime of the original owner or end-user.

Any product reported to the authorized dealer or to Kraus as being defective within the warranty period will be repaired or replaced with a product of equal value at the option of Kraus. This warranty extends to the original owner or end-user, and is not transferable to a subsequent owner.

### Restrictions

This warranty does not cover antediluvian, discontinued, or display products, whether such items are purchased at discount outlets, unauthorized dealers, and/or sold on clearance.

This warranty does not cover instances of negligence, misuse, abuse, improper installation, carelessness, accident, hard water or mineral deposits, exposure to corrosive materials, misapplication, damages caused by improper maintenance, alteration of the product, or failure to follow care or installation instructions enclosed with your product. Avoid using abrasive cleaners such as powders, bleach, ammonia, alcohol, or chlorine. Avoid using abrasive pads, steel wool, or wire brushes, as these will damage and wear down the finish.

This warranty does not apply to Products that have not been installed or operated in accordance with instructions supplied by Kraus and all applicable rules, regulations, and legislation pertaining to such installations.

This warranty does not apply unless the Kraus product is installed by a fully insured and licensed trade professional. Kraus insists that such professionals have experience in the installation of bathroom and kitchen manufactured goods.

This warranty does not cover labor charges or costs of removal and reinstallation of said product. This warranty does not allow recovery of incidental or consequential damages, such as loss of use, delay, property damage, or other consequential damages, and Kraus accepts no liability for such damages.

This warranty does not cover Marine or Outdoor Installation.

This warranty does not cover any free gifts included with purchase.

Except as otherwise provided above, Kraus makes no warranties, expressed or implied, including warranties of merchantability and fitness for a particular purpose, or compliance with any code.

Shipping charges will be covered for the first (1) year of the warranted replacement part or product (HI, AK, and Puerto Rico shipping charges may apply). International shipping fees are not included.

## **Commercial Warranty**

Kraus extends the above warranty for a period of one (1) year to purchasers of products for industrial, commercial, and business use.

All incidental or consequential damages are specifically excluded. No additional warranties, express or implied, are given, including but not limited to any implied warranty of merchantability or fitness for a particular purpose.

Some states do not allow the exclusion or limitation of incidental or consequential damages or limitations on how long an implied warranty lasts, so the above limitations or exclusions may not apply to you.

This warranty gives you specific legal rights, and you may also have other rights which vary from state to state.

KRAUS USA has the right to change, modify, and/or update the warranty policy at any time. For the latest, most up to date comprehensive warranty, go to [www.kraususa.com/warranty](http://www.kraususa.com/warranty)

### **If you are a homeowner, please contact a Kraus Customer Service Representative at:**

Kraus USA, Inc.  
12 Harbor Park Drive  
Port Washington, NY 11050  
Toll-Free : 800-775-0703  
[Customerservice@kraususa.com](mailto:Customerservice@kraususa.com)

### **If you are a plumbing contractor or trade professional, please contact a Kraus Pro Representative at:**

Kraus USA, Inc.  
12 Harbor Park Drive  
Port Washington, NY 11050  
516-801-8955  
[Proservice@kraususa.com](mailto:Proservice@kraususa.com)

### **If you are an authorized partner, please contact a Partner Support Representative at:**

Kraus USA, Inc.  
12 Harbor Park Drive  
Port Washington, NY 11050  
516-801-8954  
[Partnersupport@kraususa.com](mailto:Partnersupport@kraususa.com)

### **In requesting warranty service, please be ready to provide:**

1. Proof of purchase.
2. A description of the problem.

**Download the Kraus Care & Maintenance Guide at:**

<http://www.kraususa.com/maintenance>

# IMPORTANT

## Register Your Kraus Product

**Activate** Your Warranty

**Access** Premium Customer Support

**Get** Product Information

**REGISTER TODAY**

<http://www.kraususa.com/registration>



**Kräus**<sup>®</sup>  
www.kraususa.com





# Food Waste Disposer

KWD100-75, KWD100-100

## **Congratulations on the purchase of your new Kraus® plumbing fixture!**

Please keep the box and packaging materials until your product is completely installed. If you have any questions, require technical assistance or have any problems with your product:



**DO NOT RETURN TO STORE**

**Please contact our Customer Service Team  
1-800-775-0703 / [customerservice@kraususa.com](mailto:customerservice@kraususa.com)**

Have the model number available and retain a copy of your receipt with purchase date for reference.

If for any reason this product does not meet your expectations, please be sure to repack this product in the original box and packaging material to avoid damage during transit.



**⚠️ WARNING** – When using electric disposers, basic precautions are always to be followed, including the following:

1. Read all the instructions before using the disposer.
2. To reduce the risk of injury, close supervision is required when a disposer is used near children.
3. Do not put fingers or hands into a disposer.
4. Turn the power switch to the off position before attempting to clear a jam or remove an object from the disposer.
5. When attempting to loosen a jam in a disposer, use a long wooden object such as a wooden spoon or the wooden handle of a broom or mop.
6. When attempting to remove objects from a disposer use long-handled tongs or pliers. For a disposer that is magnetically actuated, use nonmagnetic tools.
7. To reduce the risk of injury by materials that are expellable by a disposer, do not put the following into a disposer:
  - a. Clam or oyster shells.
  - b. Caustic drain cleaners or similar products.
  - c. Glass, porcelain, or plastic.
  - d. Large whole bones.
  - e. Metal, such as bottle caps, tin cans, or utensils
  - f. Hot grease or other hot liquids.
8. When not operating a disposer, leave the drain cover in place to reduce the risk of objects falling into the disposer.

**SAVE THESE INSTRUCTIONS**

**Download the Kraus Care & Maintenance Guide at:**  
<http://www.kraususa.com/maintenance>

# Dimensions

---

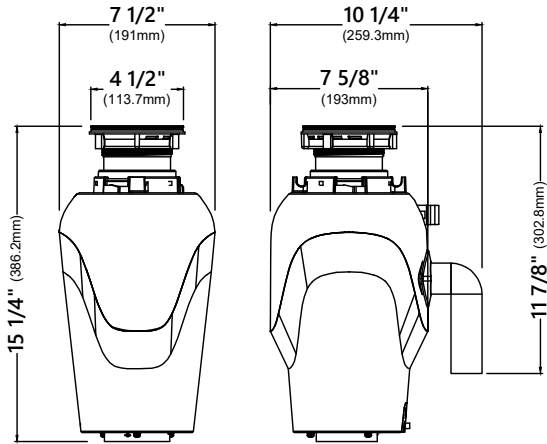

**KWD100-75**

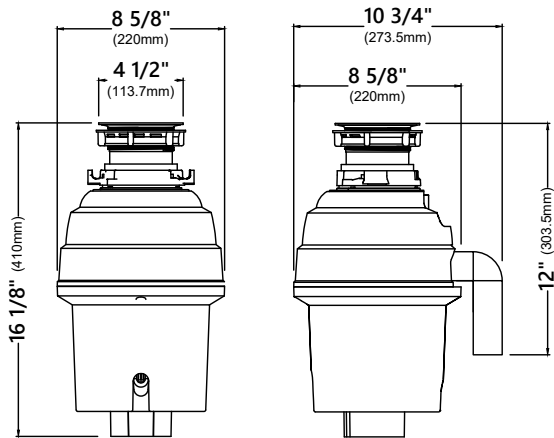

**KWD100-100**

## Grounding Instructions

---

This disposer must be grounded to reduce the risk of electric shock in the event of a malfunction or breakdown. Grounding provides a path of least resistance for electric current. This disposer is equipped with a cord having an equipment-grounding conductor and a grounding plug. The plug must be plugged into an outlet that is properly installed and grounded in accordance with all local codes and ordinances. **WARNING** – Improper connection of the equipment-grounding conductor can result in a risk of electric shock. Check with a qualified electrician or serviceman if you are in doubt as to whether the disposer is properly grounded. If the plug provided with the disposer does not fit the outlet, do not modify it.

### See insert for specific information about your new disposer

---

**NOTE:** This Food Waste Disposer has been designed to operate on 110 Volt, 60 Hz exclusively. Using any other voltage or Hz adversely affects performance.

**IMPORTANT:** Read all instructions thoroughly. Keep this guide for future reference.

**CAUTION:** Be sure to review SAFETY INSTRUCTIONS FIRST PERTAINING TO A RISK OF FIRE, ELECTRICAL SHOCK OR INJURY TO PERSONS before using disposer.

### Record important disposer information here

---

Bill of sale, sales slip, cancelled check or other purchase record should be kept to verify the original purchase date for warranty purposes.

**Model Number\***

**Batch Number\***

---

\*Above information appears on the label affixed to bottom of the disposer. For your convenience, write down the model and batch numbers prior to installation.

# Tools You May Need

---

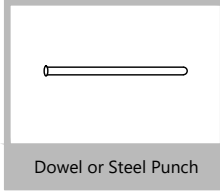
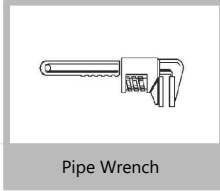
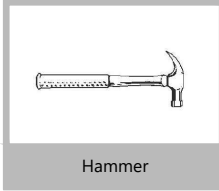
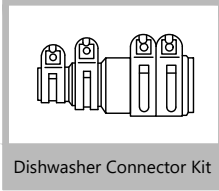
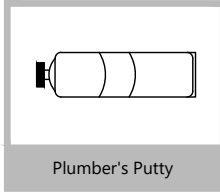
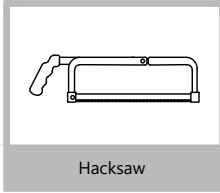
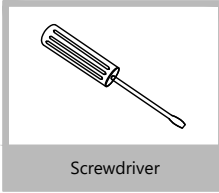

# Important Safety Instructions

---

## INSTRUCTIONS PERTAINING TO A RISK OF FIRE, ELECTRIC SHOCK OR INJURY TO PERSONS. SAVE THESE INSTRUCTIONS.

**WARNING** – When using electrical appliances, basic precautions should always be followed, including the following:

1. Read all instructions before using the appliance.
2. To reduce the risk of injury, close supervision is necessary when an appliance is used near children.
3. Do not put fingers or hands into a waste disposer.
4. Turn the power switch to the off position before attempting to clear a jam or remove an object from the disposer.
5. When attempting to loosen a jam in a waste disposer, use a long wooden object such as a wooden spoon or the wooden handle of a broom or mop.
6. When attempting to remove objects from a waste disposer use long-handled tongs or pliers. If the disposer is magnetically actuated, non-magnetic tools should be used.
7. To reduce the risk of injury by materials that may be expelled by a waste disposer, do not put the following into a disposer: clam or oyster shells; caustic drain cleaners or similar products; glass, porcelain or plastic; large whole bones; metal, such as bottle caps, tin cans, aluminum foil or utensils; hot grease or other hot liquids; whole cornhusks.
8. When not operating a disposer, leave the stopper in place to reduce the risk of objects falling into the disposer.
9. DO NOT operate disposer unless splash guard is in place. (Does not apply to the Top Control/Batch Feed units.)
10. For proper grounding instructions see the ELECTRICAL CONNECTION portion of this manual.

## Step 1. Removal of Old Unit

Before starting this step, turn off electrical power at the circuit breaker or fuse box. If your old mount is the same as the mount on your new disposer, just reverse the assembly instructions found in section 3. If your new mount system is different, follow these instructions:

- A. Use a pipe wrench to disconnect drain line where it attaches to disposer discharge tube (see 1A).
- B. Remove disposer from sink flange by turning mount ring to the left clockwise (see 1B). If you are unable to turn the mount ring, tap on one of the extensions from the ring with a hammer. Some mounting systems have tubular extensions. Inserting a screwdriver into one tube will provide additional leverage for turning the mount ring (see 1B). Some disposers may require the removal or loosening of nuts from the mount screws (see 1C). Some disposers may require the removal of a clamp.  
**CAUTION:** Be sure to support the disposer while performing this step or it may fall when the mounting ring is disconnected from the mounting assembly. If your disposer is hard wired (metal shielded cable not utilizing a wall plug), complete steps C and D. If you utilize a plug-in cord, go on to step E.
- C. When disposer is removed, turn up side down and remove electrical cover plate (see 1D).
- D. Use screwdriver to remove green ground wire. Remove wire nuts from black and white power wires and separate disposer wires from power cable wires. Loosen screws on cable clamp and separate cable from disposer.
- E. To remove remaining mount system from the sink, loosen mount screws, push mount ring up. Under it is the snap ring. Use screwdriver to pop off ring (see 1E). Remove mount ring, protector ring and gasket from sink flange. Some mounts will require the unscrewing of a large ring holding the sink flange in place. Pull sink flange up through sink and clean off old putty from sink.

**IMPORTANT:** Unless you have a new home, this is a good time to clean out the trap and drain lines by running a drain auger or plumber's snake before installing your new disposer.

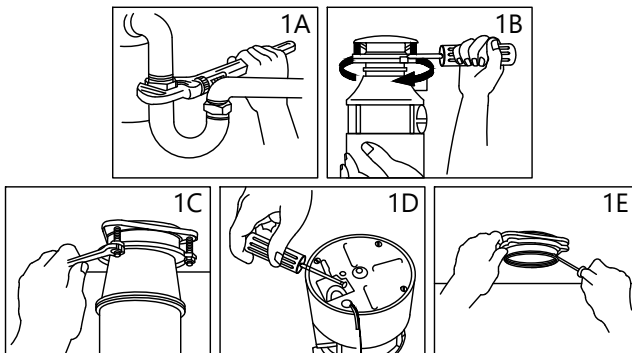

## Step 2. Dishwasher Connection

If you are utilizing a dishwasher, complete the following procedure. If dishwasher is not to be connected go on to section 3.

- A. Make use of a blunt instrument to knock out the housing cap(see 2A1), please sure to use a steel punch or wooden dowel but not sharp instrument. Punch the cap with force and remove the fell off cap(see 2A2). Use the blunt instrument again to knock the plug on the inner body(see 2A3). Please take out or grind the knockout plug if it falls into the chamber.
- B. Connect dishwasher hose using hose clamp. If hose size is different, you will need a Dishwasher Connector Kit (see 2B). Make sure all plumbing connections are tight and in accordance with all plumbing codes and ordinances. Run water and check for leaks.

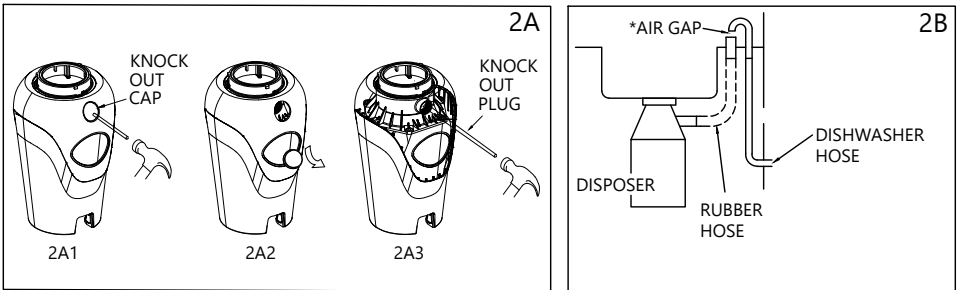

\*Air gap may not be required for all installations. Check local plumbing codes.

## Step 3. Installation of Mounting Assembly

Your disposer comes with the EZ Mount System.

### EZ Mount System

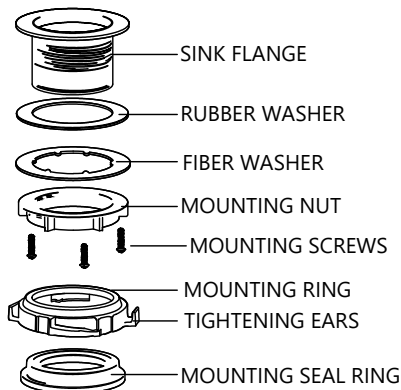



## READ COMPLETELY BEFORE STARTING

**NOTE:** Pay close attention to the order of mount assembly parts, as they have been correctly assembled by the factory. Also, reference the cushion mount detail in illustration 3D below for the proper orientation of the cushion mount.

**NOTE:** Try practicing this assembly before you get under the sink to get the "feel" of how the parts fit together.

- A. Disassemble mount assembly from disposer by turning mounting ring to the left (counterclockwise) and remove.
- B. Raise mounting ring toward top of sink flange. Remove mounting seal ring. Remove mounting ring. You may want to practice installing the mounting seal ring at this point before you are under the sink. See paragraph H. Also see the "Important Notice: Mounting Seal Ring Detail."
- C. Unscrew mounting nut from sink flange and remove fiber washer. You are now left with sink flange and rubber washer.
- D. The rubber washer is used instead of plumbers putty with stainless steel sinks. Other sinks will require putty.
- E. If no putty is used, insert sink flange through rubber washer into sink opening. Do not rotate sink flange once it is seated.
- F. If you use putty instead of the washer, form a ring around underside of sink flange. Insert flange into sink opening, press down hard to squeeze out excess putty. From under sink, trim off excess putty flush with bottom edge of sink opening.
- G. From underneath sink, slip fiber washer onto exposed sink flange. With arrows pointing up, screw mounting nut onto the sink flange, hand tighten until the sink flange will not move (see 3A). Tighten mounting screws. At this point you may want to insert stopper in sink and fill with water to check sink flange seal and insure there are no leaks.
- H. Place mounting ring over sink flange and hold in place while installing mounting seal ring (large side down) so the groove on the inside of mounting seal ring fits over lip on sink flange, similar to putting the lid on a plastic container (see 3B, 3C & 3D). Please read important notice below.

### Important Notice: Mounting Seal Ring Detail

When the mounting seal ring is installed correctly, the lip of the sink flange fits into the groove on the inside of the mounting seal ring and mounting ring can be pulled downward over mounting seal ring and will be free to rotate. The bottom bead of the mounting seal ring acts as a gasket between the bottom of the sink flange and the top of the disposer. See illustration 3D.

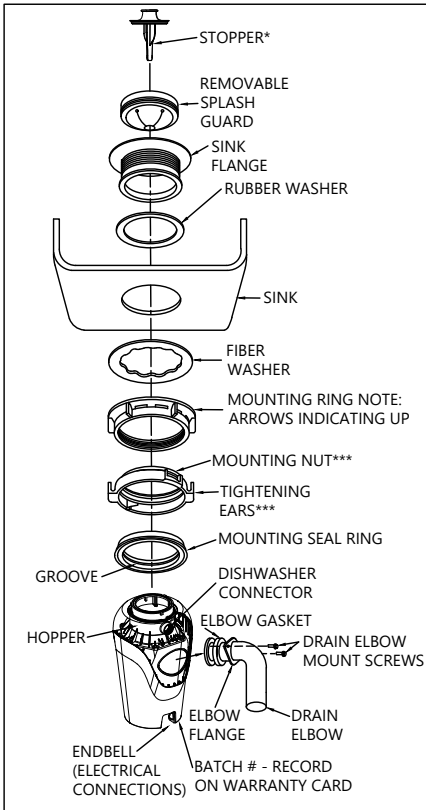
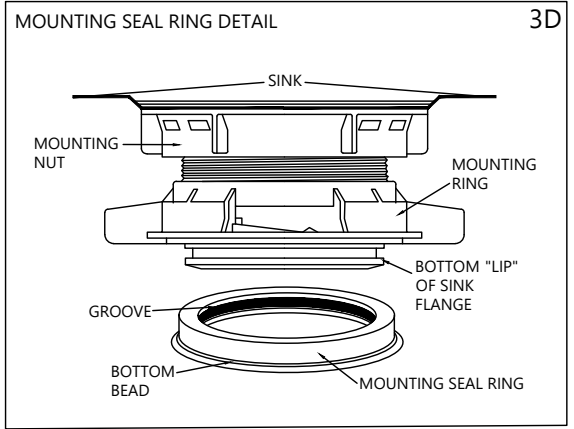
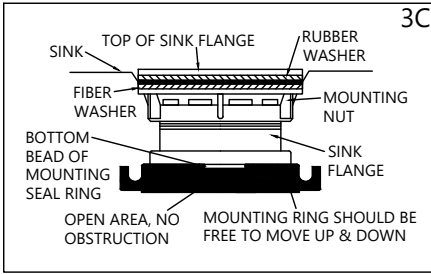
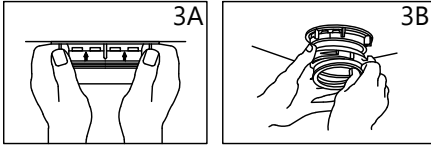

\*Batch Feed Stopper looks different than the stopper illustrated.  
 \*\*NOT used with Batch Feed units.  
 \*\*\*Your mounting nut may look different and not have tightening ears.

## Step 4. Electrical Connections

---

Now is the time to record the BATCH NUMBER (located on the bottom of the disposer) onto the warranty card.

**IF YOU ARE NOT FAMILIAR WITH ELECTRICAL POWER AND PROCEDURES, CALL A QUALIFIED ELECTRICIAN.**

**WARNING:** Improper connection of the equipment grounding conductor can result in a risk of electric shock. Check with a qualified electrician or service man if you are in doubt as to whether the appliance is properly grounded. Do not modify the plug provided with the appliance if it will not fit the outlet, have a proper outlet installed by a qualified electrician.

## Step 5. Attaching Drain Elbow

---

- A. Connect drain elbow to the disposer (see 5A), proceed to step 6 and then connect bottom of the elbow by tightening the slip nut (see 5B).
- B. If you are connecting to a dishwasher, return to section 2B. If not, make sure all plumbing connections are tight and in accordance with all plumbing codes and ordinances. Run water and check for leaks.

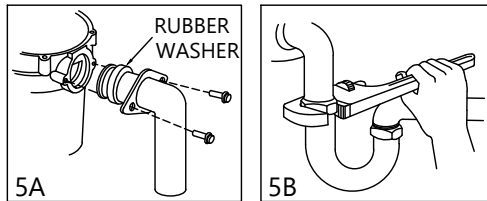

## Step 6. Connecting Disposer to Mount Assembly

### EZ Mount

- A. Line up disposer under mounting assembly. Guide hopper projections into mounting ring slots. Turn mounting ring about  $1/4"$  to right so that disposer is temporarily supported (see 6A).
- B. Turn mounting ring and disposer until drain elbow lines up with trap (see 6B).
- C. Turn mounting ring to the right (clockwise) until it locks up tight. Tap the mounting ring ears with a hammer until the lock position is achieved. Hopper projections must be to extreme left of mounting slots (see 6C).
- D. If mounting ring is hard to turn, you may add a small amount of petroleum jelly or liquid soap to hopper projections. Run water and check for leaks.

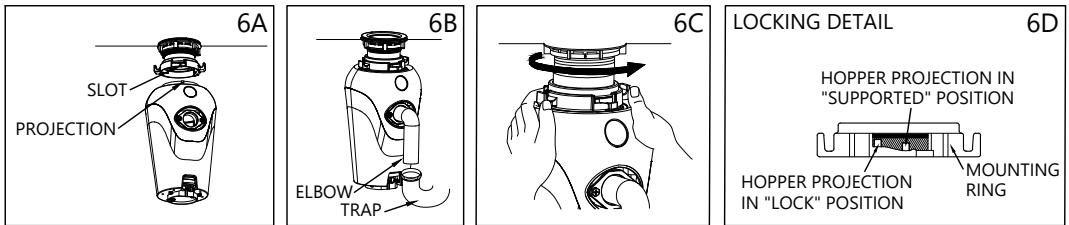

## Step 7. Operating Instructions

The Anti-Jam Swivel Impellers make a clicking sound as they swing into place. This indicates normal operation.

- A. Remove sink stopper. Turn on a medium flow of cold water.
- B. Turn switch to ON position; your motor is turning at full speed and ready to use.
- C. Scrape in food waste. Down the drain go table scraps, peelings, rinds, seeds, pits, small bones and coffee grounds. To speed up food waste disposal, cut or break up large bones, rinds and cobs. Large bones and fibrous husks require considerable grinding time and are more easily thrown away with other trash. Do not be alarmed that the disposer slows down while grinding. The disposer is actually increasing torque (grinding power) and is operating under normal conditions.
- D. Before turning disposer off, let water and disposer run for approximately 15 seconds after shredding stops. This assures that all waste is thoroughly flushed through trap and drain.
- E. It is not recommended to use hot water while running disposer. Cold water will keep waste and fats solid so disposer can flush away particles.

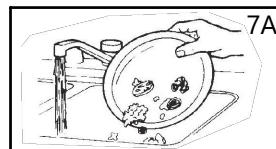

## TIPS FOR SUCCESSFUL OPERATION

- A. Be sure disposer is empty before using your dishwasher so it may drain properly.
- B. You may want to leave the stopper in the drain when not in use to prevent utensils and foreign objects from falling into the disposer.
- C. Your disposer is ruggedly built to give you many years of trouble free service. It will handle all normal food wastes, but it will NOT grind or dispose of such items as plastic, tin cans, bottle caps, glass, china, leather, cloth, rubber, string, clam and oyster shells, aluminum foil or feathers.

# Replacement Parts

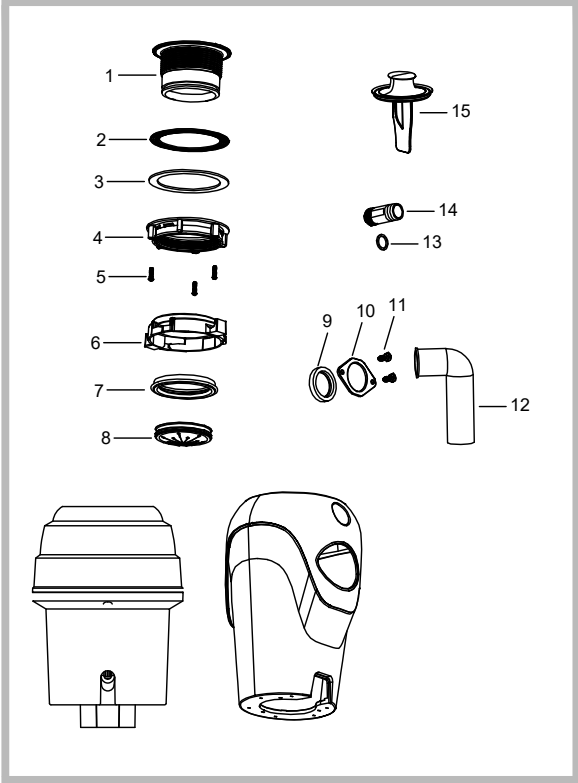

Replacement Parts List	Part #
1. Sink Flange	KP52000
2. Rubber Washer	KP52001
3. Fiber Washer	KP52002
4. Mounting Nut	KP52003
5. Mounting Screw x 3	KP52004
6. Mounting Ring	KP52005
7. Mounting Seal Ring	KP52006
8. Splash Guard	KP52007
9. Drain Elbow Washer	KP52008
10. Drain Elbow Press	KP52009
11. Drain Elbow Mount Screw	KP52010
12. Drain Elbow	KP52011
13. Dishwasher Connector O-Ring	KP52012
14. Dishwasher Connector	KP52013
15. Drain Stopper/Pusher	KP52014

## Troubleshooting

Before seeking repair or replacement, we recommend that you review the following:

**LOUD NOISES:** (Other than those during grinding of small bones and fruit pits): These are usually caused by accidental entry of a spoon, bottle cap or other foreign objects. To correct this, turn off electrical switch and water. After disposer has stopped, remove \*splash guard, remove object with long handled tongs, and replace \*splash guard.

**UNIT DOES NOT START:** Unplug power cord or turn either the wall switch or breaker box switch to "°OFF"± position, depending on your model and wiring configuration. Remove stopper and/or \*splash guard. Check to see if turntable will rotate freely using a wooden broom handle. If turntable rotates freely, replace \*splash guard and check re-set button to see if it has been tripped. Re-set button is red and located opposite discharge elbow, near the bottom (see 8A). Push button in until it clicks and remains depressed. If re-set button has not been tripped, check for shorted or broken wire connecting to disposer. Check electrical power switch, fuse box or circuit breaker. If wiring and electrical components are intact, the unit may have internal problems that require service or replacement.

\* - Splash guard not used on Top Control/Batch Feed unit.

**IF TURNTABLE DOES NOT ROTATE FREELY:** Turn off disposer, then check for any foreign objects lodged between the turntable and grind ring. Dislodge object by rotating table with a wooden broom handle and remove object (see 8B). If no foreign object is present, there may be internal problems.

**LEAKS:** If the unit leaks at the top, it may be due to:

1. Improper seating of sink flange (gasket centering, putty or tightening).
2. Support ring not tightened properly.
3. Defective or improperly installed cushion mount. If unit leaks at the waste elbow, leak may be due to improper tightening of elbow flange screws.

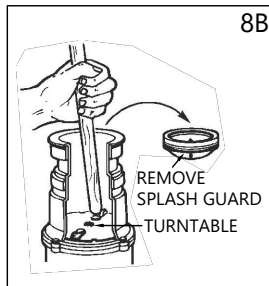
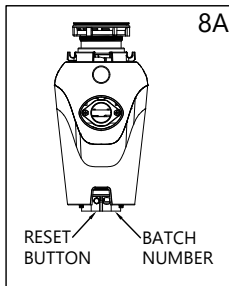

## Cleaning and Maintenance

### DO NOT ATTEMPT TO LUBRICATE YOUR DISPOSER!

The motor is permanently lubricated. The disposer is self cleaning and scours its internal parts with each use. **NEVER** put lye or chemical drain cleaners into the disposer, as they cause serious corrosion of metal parts. If used, resulting damage can be easily detected and all warranties are void. Mineral deposits from your water can form on the stainless steel turntable, giving the appearance of rust. **DO NOT BE ALARMED**, the stainless steel turntables used will not corrode.

## Codes/Standards Applicable:



### **Food Waste Disposer - Limited Warranty**

Kraus®USA Plumbing, LLC extends this warranty to the original purchasers of the Food Waste Disposer (the "Product") when purchased from an authorized Kraus dealer and in the location of original installation. This warranty only applies to Product installed in the United States and Canada. This warranty is non-transferable.

For personal household use, Kraus warrants the Product to be free from defects in material and workmanship under normal usage for a period of five (5) years from the date of purchase from an authorized Kraus dealer.

Any product reported to the authorized dealer or to Kraus as being defective within the warranty period will be repaired or replaced with a product of equal value at the option of Kraus.

### What is Not Covered

This warranty does not cover Products that were discontinued when purchased or display Products, whether such Products were purchased at discount outlets, unauthorized dealers, and/or sold on clearance. This warranty does not cover any free gifts included with purchase.

This warranty does not cover reasonable wear and tear from ordinary use, including cosmetic rust, scratches or dents.

This warranty does not cover damage resulting from neglect, misuse (including use for an unintended application), abuse, carelessness, accident, hard water or mineral deposits, exposure to corrosive materials, outdoor use, improper maintenance, alteration of the Product, leaks at the sink flange, dishwasher inlet or discharge elbow, excessive torquing of the Product's screws, or failure to follow care, cleaning or installation instructions enclosed with your Product. Kraus recommends that all Kraus Products be installed by a fully licensed and insured trade professional with experience in the installation of kitchen manufactured goods.



## How to Make a Warranty Claim

If you are a **consumer purchaser**, please contact a Kraus Customer Service Representative at:

Kraus® USA Plumbing, LLC  
12 Harbor Park Drive  
Port Washington, NY 11050  
Toll-free 800-775-0703  
Customerservice@kraususa.com

If you are a **plumbing contractor or trade professional**, please contact a Kraus Pro Representative at:

Kraus USA Plumbing, LLC  
12 Harbor Park Drive  
Port Washington, NY 11050  
516-801-8955  
Proservice@kraususa.com

If you are an **authorized partner**, please contact a Partner Support Representative at:

Kraus USA Plumbing, LLC  
12 Harbor Park Drive  
Port Washington, NY 11050  
516-801-8954  
Partnersupport@kraususa.com

In requesting warranty service, please be ready to provide your proof of purchase and a description of the problem. Shipping charges will be covered for the first (1) year of the warranted replacement part or product (HI, AK, and Puerto Rico shipping charges may apply). International shipping fees are not included.

## Limitation on Duration of Implied Warranties

Please note that some states/provinces (including Quebec) do not allow limitations on how long an implied warranty lasts, so the below limitations may not apply to you. TO THE MAXIMUM EXTENT PERMITTED BY APPLICABLE LAW, ANY IMPLIED WARRANTY, INCLUDING THE IMPLIED WARRANTIES OF MERCHANTABILITY AND OF FITNESS FOR A PARTICULAR PURPOSE, IS LIMITED TO THE STATUTORY PERIOD OR THE DURATION OF THIS WARRANTY, WHICHEVER IS SHORTER.

## Limitation of Special, Incidental or Consequential Damages

Please note that some states/provinces (including Quebec) do not allow the exclusion or limitation of special, incidental or consequential damages, so the below limitations and exclusions may not apply to you. TO THE MAXIMUM EXTENT PERMITTED BY APPLICABLE LAW, THIS WARRANTY DOES NOT COVER, AND KRAUS USA PLUMBING, LLC SHALL NOT BE LIABLE FOR, ANY SPECIAL, INCIDENTAL OR CONSEQUENTIAL DAMAGES (INCLUDING LABOR CHARGES TO REPAIR, REPLACE, INSTALL OR REMOVE THIS PRODUCT), WHETHER ARISING OUT OF BREACH OF ANY EXPRESS OR IMPLIED WARRANTY, BREACH OF CONTRACT, TORT, OR OTHERWISE.

This warranty gives you specific legal rights, and you may also have other rights which vary from state/province to state/province.

# IMPORTANT

## Register Your Kraus® Product

**Activate** Your Warranty

**Access** Premium Customer Support

**Get** Product Information

**REGISTER TODAY**

<http://www.kraususa.com/registration>



**Kräus®**  
www.kraususa.com



INSTALLATION GUIDE

## Kitchen Strainer

ST-1 / ST-2 / ST-3 / BST-1 / BST-2

## **Congratulations on the purchase of your new Kraus plumbing fixture!**

Please keep the box and packaging materials until your product is completely installed. If you have any questions, require technical assistance or have any problems with your product:



**DO NOT RETURN TO STORE**

**Please contact our Customer Service Team  
1-800-775-0703 / [customerservice@kraususa.com](mailto:customerservice@kraususa.com)**

Have the model number available and retain a copy of your receipt with purchase date for reference.

If for any reason this product does not meet your expectations, please be sure to repack this product in the original box and packaging material to avoid damage during transit.

### **Prior to Installation:**

- Make sure you have all necessary parts by checking the diagram and parts list. If any part is missing or damaged, please contact Kraus Customer Service at 800-775-0703 for a replacement.

**For technical assistance or replacement parts, please contact Kraus Customer Service and one of our representatives will be happy to help:**  
Toll-Free: 800-775-0703 or [Customerservice@kraususa.com](mailto:Customerservice@kraususa.com)

The step-by-step guidelines in the installation instructions are a general reference for installing a Kraus Sink. Should there be any discrepancies, Kraus cannot be held liable. It is recommended to install all Kraus products by hiring a licensed professional.

### **Tools you will need:**



Safety Goggles



Phillips Screwdriver

## Diagram and Parts List

ST-1

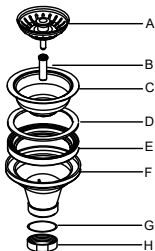

- A. Strainer Cover
- B. Screw
- C. Metal Strainer
- D. Foam Gasket
- E. Rubber Gasket
- F. Main Body
- G. Drain Gasket
- H. Drain Nut

ST-2

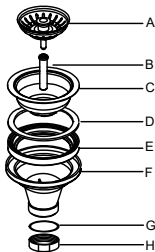

- A. Strainer Cover
- B. Screw
- C. Metal Strainer
- D. Foam Gasket
- E. Rubber Gasket
- F. Main Body
- G. Drain Gasket
- H. Drain Nut

## Diagram and Parts List

BST-1

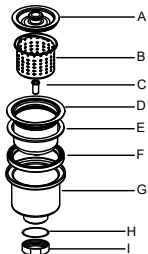

- A. Strainer Cover
- B. Basket
- C. Screw
- D. Metal Strainer
- E. Foam Gasket
- F. Rubber Gasket
- G. Main Body
- H. Drain Gasket
- I. Drain Nut

BST-2

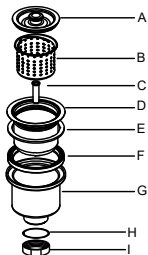

- A. Strainer Cover
- B. Basket
- C. Screw
- D. Metal Strainer
- E. Foam Gasket
- F. Rubber Gasket
- G. Main Body
- H. Drain Gasket
- I. Drain Nut

## Diagram and Parts List

ST-3

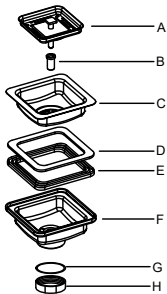

- A. Strainer Cover
- B. Screw
- C. Metal Strainer
- D. Foam Gasket
- E. Rubber Gasket
- F. Main Body
- G. Drain Gasket
- H. Drain Nut



## Dimensions

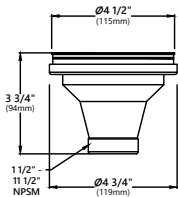

Model #: ST-1  
Dimensions:  $\varnothing 4 \frac{1}{2}'' \times 3 \frac{3}{4}''$

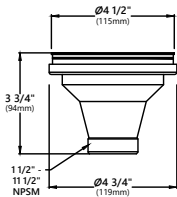

Model #: ST-2  
Dimensions:  $\varnothing 4 \frac{1}{2}'' \times 3 \frac{3}{4}''$

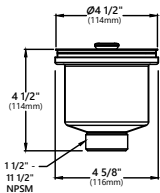

Model #: BST-1  
Dimensions:  $\varnothing 4 \frac{1}{2}'' \times 4 \frac{1}{2}''$

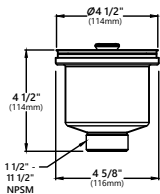

Model #: BST-2  
Dimensions:  $\varnothing 4 \frac{1}{2}'' \times 4 \frac{1}{2}''$

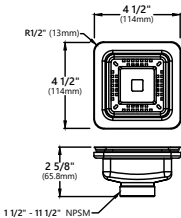

Model #: ST-3  
Dimensions:  $4 \frac{1}{2}'' \times 4 \frac{1}{2}'' \times 2 \frac{5}{8}''$

## Step 1.

---

Disassemble strainer



## Step 2.

---

Insert metal strainer into drain hole with foam gasket attached. Install rubber gasket and main body underneath the sink

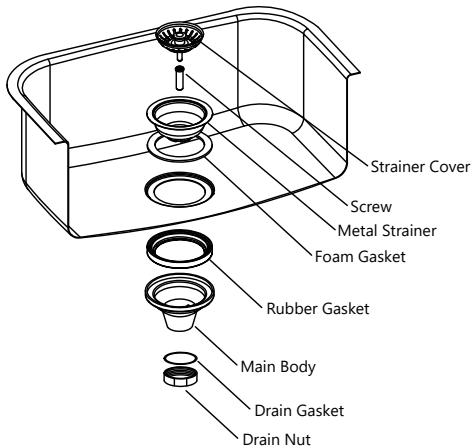

Step 3.

---

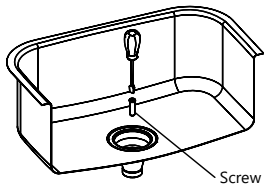

Using the screw, tighten the metal strainer and main body into place

Step 4.

---

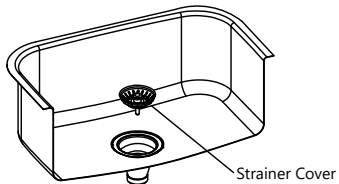

Insert strainer cover to seal water

## Replacement Parts

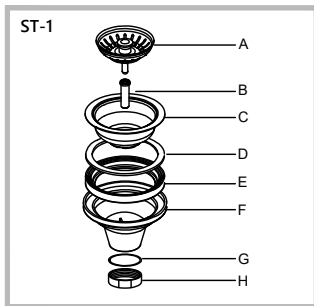

Replacement Parts List	Finish	Part #
A. Strainer Cover	SS*	KPU00010
A. Strainer Cover	PGM*	KPU00010-PGM
B. Screw 1 1/4"	SS*	KPU00003
B. Screw 1 1/4"	PGM*	KPU00003-PGM
C. Metal Strainer	SS*	KPU00011
C. Metal Strainer	PGM*	KPU00011-PGM
D. Foam Gasket		KPU00005
E. Rubber Gasket		KPU00006
F. Main Body		KPU00012
G. Drain Gasket		KPU00008
H. Drain Nut		KPU00009

\*Denotes faucet component color options:

SS - Stainless Steel

PGM - PVD Gunmetal

## Replacement Parts

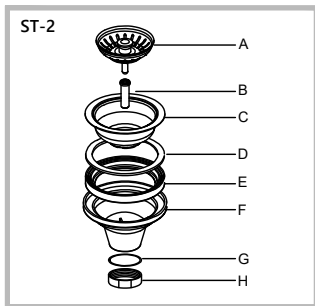

Replacement Parts List	Finish	Part #
A. Strainer Cover		KPU00010
B. Screw 1 5/8"		KPU00013
C. Metal Strainer		KPU00011
D. Foam Gasket		KPU00005
E. Rubber Gasket		KPU00006
F. Main Body		KPU00012
G. Drain Gasket		KPU00008
H. Drain Nut		KPU00009

## Replacement Parts

**BST-1**

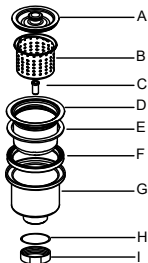

Replacement Parts List	Finish	Part #
A. Strainer Cover		KPU00001
B. Basket		KPU00002
C. Screw 1 1/4"		KPU00003
D. Metal Strainer		KPU00004
E. Foam Gasket		KPU00005
F. Rubber Gasket		KPU00006
G. Main Body		KPU00007
H. Drain Gasket		KPU00008
I. Drain Nut		KPU00009

**BST-2**

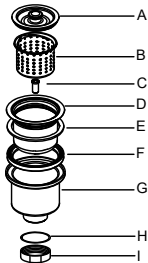

Replacement Parts List	Finish	Part #
A. Strainer Cover		KPU00001
B. Basket		KPU00002
C. Screw 1 5/8"		KPU00013
D. Metal Strainer		KPU00004
E. Foam Gasket		KPU00005
F. Rubber Gasket		KPU00006
G. Main Body		KPU00007
H. Drain Gasket		KPU00008
I. Drain Nut		KPU00009

## Replacement Parts

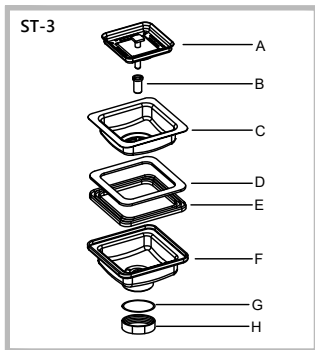

Replacement Parts List	Finish	Part #
A. Strainer Cover		KP22191
B. Screw		KP22198
C. Metal Strainer		KP22192
D. Foam Gasket		KP22193
E. Rubber Gasket		KP22194
F. Main Body		KP22195
G. Drain Gasket		KP22196
H. Drain Nut		KP22197



## **Accessories Warranty**

Kraus products are manufactured and tested to the highest quality standards by Kraus USA Inc. ("Kraus").

Kraus extends this warranty to the original purchaser for personal household use of the "Accessories" in their original location. The warranty is non-transferable.

Kraus warrants the structure and finish of the product (Accessories) to be free from defects in material and workmanship under normal usage for a period of one (1) years. The warranty commences from the initial date of purchase by the owner or trade professional, from an authorized Kraus dealer, through the one (1) year term of the original owner or end-user.

Any product reported to the authorized dealer or to Kraus as being defective within the warranty period will be repaired or replaced with a product of equal value at the option of Kraus. This warranty extends to the original owner or end-user, and is not transferable to a subsequent owner.

## **Restrictions**

This warranty does not cover antediluvian, discontinued, or display products, whether such items are purchased at discount outlets, unauthorized dealers, and/or sold on clearance.

This warranty does not cover instances of negligence, misuse, abuse, improper installation, carelessness, accident, hard water or mineral deposits, exposure to corrosive materials, misapplication, damages caused by improper maintenance, alteration of the product, or failure to follow care or installation instructions enclosed with your product. Avoid using abrasive cleaners such as powders, bleach, ammonia, alcohol, or chlorine. Avoid using abrasive pads, steel wool, or wire brushes, as these will damage and wear down the finish.

Kraus USA recommends that all Kraus products are installed by fully licensed and insured trade professionals with experience in the installation of bathroom and/or kitchen manufactured goods.

This warranty does not cover labor charges or costs of removal and reinstallation of said product. This warranty does not allow recovery of incidental or consequential damages such as loss of use, delay, property damage, or other consequential damages, and Kraus accepts no liability for such damages.

This warranty does not cover Marine or Outdoor Installation.

Except as otherwise provided above, Kraus makes no warranties, expressed or implied, including warranties of merchantability and fitness for a particular purpose, or compliance with any code.

Shipping charges will be covered for the first (1) year of the warranted replacement part or product (HI, AK, and Puerto Rico shipping charges may apply). International shipping fees are not included.

## **Commercial Warranty**

Kraus extends the above warranty for a period of one (1) year to purchasers of products for industrial, commercial, and business use.

All incidental or consequential damages are specifically excluded. No additional warranties, express or implied, are given, including but not limited to any implied warranty of merchantability or fitness for a particular purpose.

Some states do not allow the exclusion or limitation of incidental or consequential damages, or limitations on how long an implied warranty lasts, so the above limitations or exclusions may not apply to you.

This warranty gives you specific legal rights, and you may also have other rights which vary from state to state.

KRAUS USA has the right to change, modify, and/or update the warranty policy at any time. For the latest, most up to date comprehensive warranty, go to [www.kraususa.com/warranty](http://www.kraususa.com/warranty).

If you are a **HOMEOWNER**, please contact a Kraus Customer Service Representative at:

Kraus USA, Inc.  
12 Harbor Park Drive  
Port Washington, NY 11050  
Toll-Free : 800-775-0703  
Customerservice@kraususa.com

If you are a **PLUMBING CONTRACTOR OR TRADE PROFESSIONAL**, please contact a Kraus Pro Representative at:

Kraus USA, Inc.  
12 Harbor Park Drive  
Port Washington, NY 11050  
516-801-8955  
Proservice@kraususa.com

If you are an **AUTHORIZED PARTNER**, please contact a Partner Support Representative at:

Kraus USA, Inc.  
12 Harbor Park Drive  
Port Washington, NY 11050  
516-801-8954  
Partnersupport@kraususa.com

In requesting warranty service, please be ready to provide:

1. Proof of purchase
2. A description of the problem

**Download the Kraus Care & Maintenance Guide at:**  
<http://www.kraususa.com/maintenance>

# IMPORTANT

## Register Your Kraus Product

**Activate** Your Warranty

**Access** Premium Customer Support

**Get** Product Information

**REGISTER TODAY**

<http://www.kraususa.com/registration>



**Kräus**<sup>®</sup>  
www.kraususa.com