

Affinity Collection

J45L

66" X 42" X 21"

CENTER DRAIN



COMBO
HYDROTHERAPY



JETTA

DARBY

66" X 42" X 21" - OVAL (2 PERSON)

FEATURES

- 12 seamless InvisiJets including:
 - 2 back jets on each end
 - 4 body jets on each side
- 2 B.P.H. pump – 9 Amps
- 31 seamless air injectors
- 600 watt air heater
- Suitable for drop-in or undermount applications
- High gloss/high impact acrylic
- Totally insulated with polyurethane foam
- Passive warm air induction system
- Gravity flow draining for sanitary bathing
- Anti-microbial flex piping
- Pre-leveled lip
- Slip resistant bottom
- Linear drain
- LED light standard
- Electronic keypad control
- Sound absorption
- 10 year limited factory warranty

OPTIONS AVAILABLE

- Spa pillows
- 6" acrylic grab bars
- JettaWARM Heated Backrest 

COLORS AVAILABLE

Standard Color: White

Decorator Colors*: Biscuit

*Requires additional lead time

RECOMMENDED OPERATING GALLONS

Minimum: 47

Maximum: 94

*Minimum operating gallon capacity required for system operation



 JettaWarm is a surface heating system secured beneath the acrylic in a blanket of insulation to provides gentle warmth on the back rest of your tub before your bath begins.

Activates in minutes, bathers can relax from the moment they enter the tub. Soaker tubs have full backrest coverage, while a whirlpool or combo has a system designed to wrap around the hydrotherapy features and warm the acrylic where you need it.

JETTACORP.COM



Jetta guarantees that the water temperature in our insulated whirlpool baths will stay within 2 degrees of its original fill temperature for 30 minutes of use without an inline heater.

J45L

Affinity Collection **DARBY**

JETTA COMBO HYDROTHERAPY | 66" X 42" X 21" | CENTER DRAIN

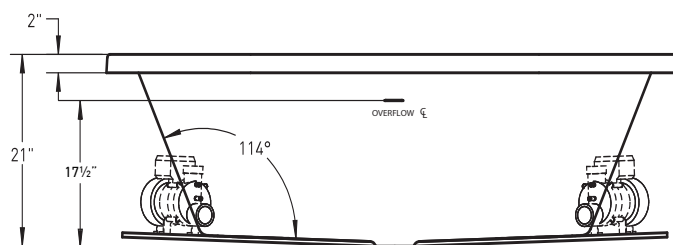
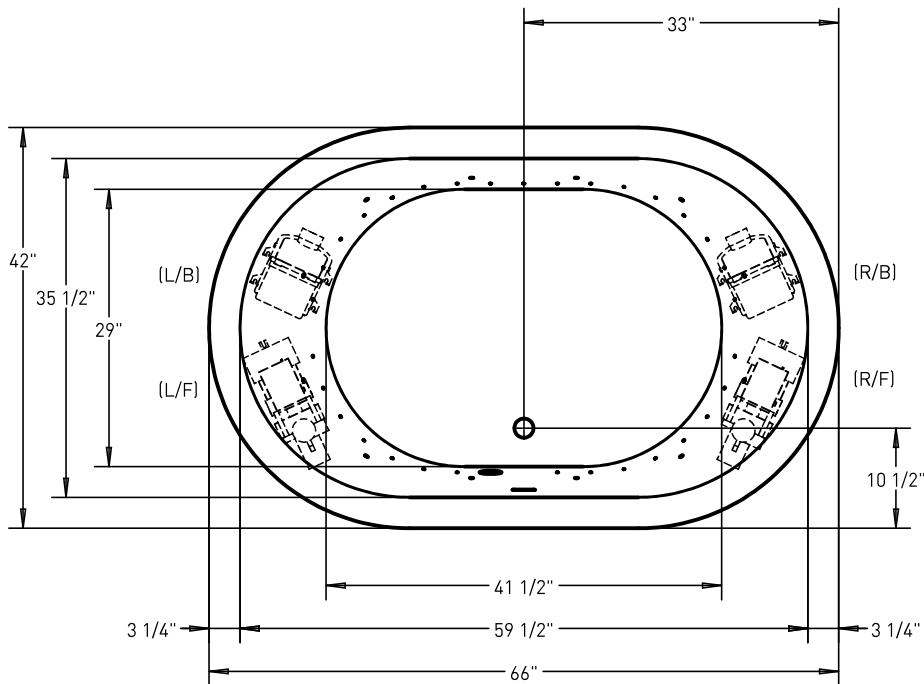

ELECTRICAL SPECIFICATIONS

Required Electrical Service 110/115 Volts
Standard Whirlpool 20 amp GFI
Standard Air 20 amp GFI
Each pump and blower must be protected by a dedicated GFI breaker (refer to local codes).

CODES/STANDARDS APPLICABLE

Specific model meets or exceeds the requirements for the following standards: ANSI, ASME.

SUGGESTED PUMP & BLOWER ACCESS PANEL

Suggested access size 20" x 12"
Actual size may vary depending on distance of access to pump & blower location.

DROP-IN CUT OUT DIMENSIONS

Template provided with tub or upon request

SHIPPING WEIGHT 185 lbs



*L/F pump, L/B blower or R/F pump, R/B blower positions are standard.
Custom pump and blower locations available upon request.

INSTALLATION: MEASURE TUB BEFORE BUILDING TUB DECK.

For best results, Jetta Corporation recommends 1"-3" of mortar bedding under the tub base for maximum support. Drawing shows manufacturer's standard pump and blower location(s). Contact Jetta for details. Dimensional variance on drawings may be +/- 1/2 inch and are subject to change without notice.

JETTACORP.COM



© 2020 Jetta Corporation. All rights reserved. Specifications are subject to change without notice.
REV 08/2020

TECHNICAL SPECIFICATIONS